

HQ SERIES: COMPACT COUNTING AND PACKAGING SOLUTIONS FOR CONFECTIONERY, FOOD AND NON-FOOD PRODUCTS

Memory flaps
for count separation and dispensing

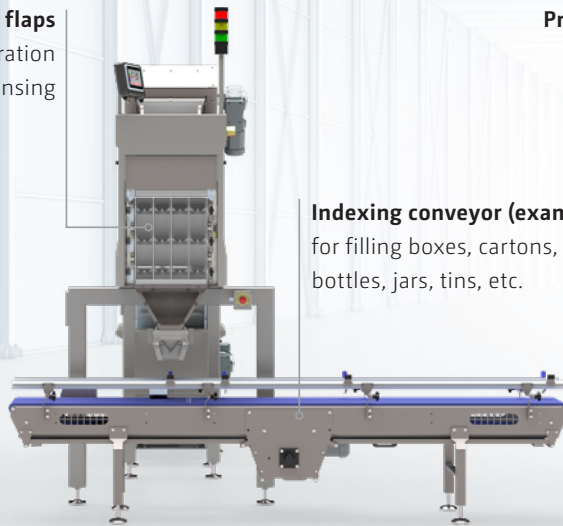

Indexing conveyor (example)
for filling boxes, cartons, tubs, bottles, jars, tins, etc.

Product detection unit
with 100% accuracy

Timing hopper
for discharging product counts

Vibratory plates
for product transport and separation

Bulk dosing system
with infeed hopper and incline dosing conveyor

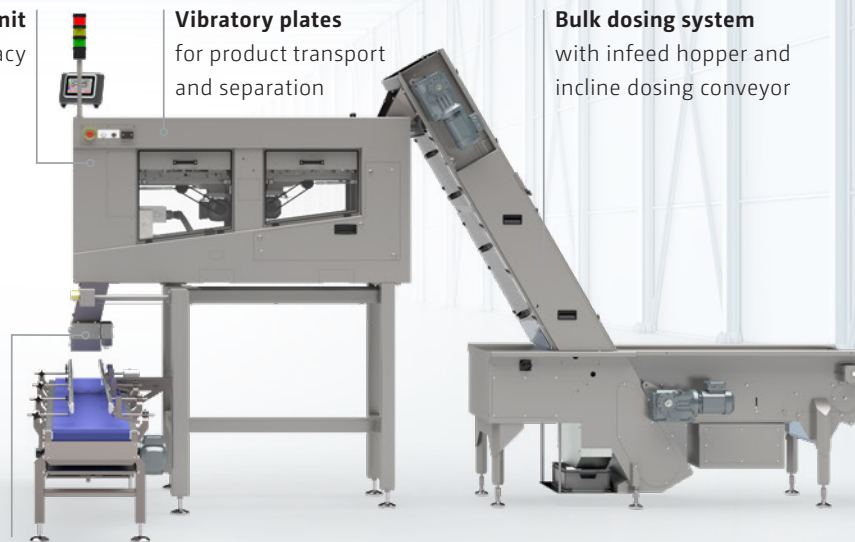

HIGHLY VERSATILE PRODUCT COUNTING SYSTEM FOR THE PRIMARY OR SECONDARY PACKAGING OF FOOD AND NON-FOOD PRODUCTS, INCLUDING MEDICAL PARTS, HARDWARE, DETERGENT POUCHES, ETC.

Basic system concept: HQ-series product counting machine with a separate product supply system and an indexing conveyor suitable for precise positioning and filling of cartons, boxes, tubs, tins, etc.

- Standard or fully custom-tailored
- Scalable output
- 100% counting accuracy
- Suited for 24/7 operation
- FDA-compliant contact parts for processing both food and non-food products
- Ease of operation and cleaning
- Low maintenance, high reliability
- Tool-free changeover, if applicable
- Silent operation, no compressed air required
- Compatible with all industrial packaging and cartoning equipment

HQ counting machine series at a glance:

Available models	HQ, HQF and HQI
Number of counting channels	4, 6, 8 or 12
Number of memory flap levels	1, 2 or 3
Nominal frame size	400 mm or 600 mm

Typical output up to 175 discharges/min. Actual output speeds are related to the number of counting channels and memory flap levels.

SOLUTIONS BEYOND COUNTING. MAXIMISING YOUR PRODUCTION EFFICIENCY THROUGH OUR EXPERIENCE, TECHNOLOGY AND DEDICATION.



**COUNTING BY THE PIECE:
TECHNOLOGY YOU CAN
COUNT ON**

Counting your products by the piece has a major advantage over counting by weight: the counting accuracy is not affected by small weight variations between individual products so that each package will always contain exactly the quantity it promises. Counting by the piece prevents product loss, avoids product wastage and maximises production efficiency. Optical counting by the piece, from bulk quantities to small sample packages containing just one or two pieces, is a proven technology with many benefits.

**PRODUCT COUNTING:
ANY PRODUCT, ANY
NUMBER, ANY PACKAGE**

The HQ series offers a fast, reliable and cost-efficient solution for the counting and packaging of unmixed, single type or single flavour products. The counting machine can be placed directly on top of a packaging machine for the filling of bags or placed over a conveyor belt to discharge the product counts into all sorts of different packagings. The versatility of the counting machine extends to the possibility of counting a large variety of different products in bulk quantities or single piece discharges into any package.

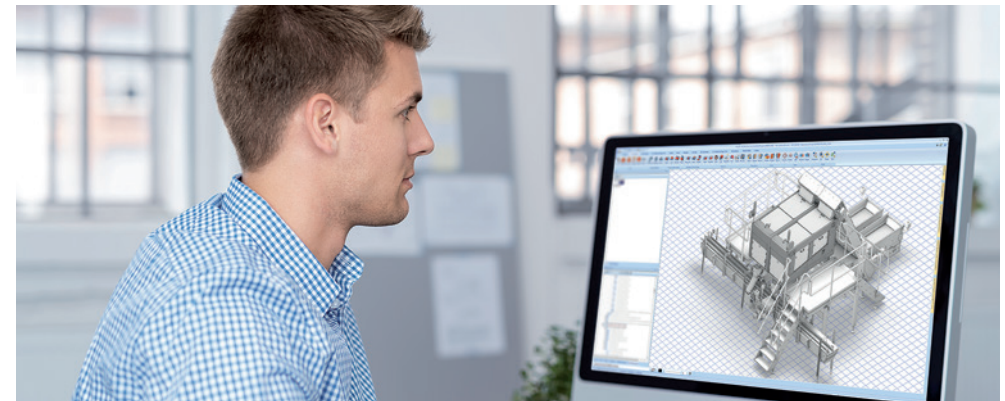

**CUSTOM SOLUTIONS:
TAILORED TO YOUR
REQUIREMENTS**

Everything can be counted. That is our initial reaction when a customer needs an automated system for packaging their products. Whether the best solution is a basic stand-alone counting machine or a more complex packing line to meet more demanding requirements, our experienced engineers always seek the most straightforward and cost-efficient solution. Our mission is to offer our customers the perfect counting and packaging solution for their products and to serve them over its entire service life.

**CREMER: WE HELP OUR
CUSTOMERS KEEP THEIR
PROMISE**

Technology and innovation are our core competences and are key to consolidating our global market position. We seek to develop top solutions which will inspire the market and allow us to stay ahead of the technology curve. Our customers range from small family businesses and medium-sized production facilities to leading multinational companies all over the world. Our daily effort is to ensure that companies can count and package their products in a 100% accurate, fast and profitable way.